

Item	Part number	Title	Qty	Item	Part number	Title	Qty
7	HSU-0047	VICE SUPPORT ASSEMBLY	1	1	HCT-17.36.20-4SL-2N-R1-01	SPRING LOADED DRAWER CABINET 4X DRAWERS	1
8	HSU-22.19.16-01	SUPPORT BRIEFCASE MODULE	1	2	HET-01.36.20-01	WORK BENCH	1
9	HSU-22.48.18-01	SUPPORT DRAWER MODULE	1	3	HAC-24.36.01-01	PEGBOARD	1
10	HSU-22.44.18-01	SUPPORT DRAWER MODULE	1	4	HCT-40.22.18-8SL-2N-R1-01	8X DRAWER MODULE SPRING LOADED FACE	2
11	HSU-22.36.20-01	SUPPORT DRAWER MODULE	1	5	HSV-46.19.16-CF-8-01	BRIEFCASE MODULE 8X (CRAFTSMAN - CMST14520)	1
12	MARANDA V365 8'	MARANDA FIBERGLASS BOX V365 8'	1	6	HMT-44.48.18-3L-3S-4-01	SHELF MODULE	1

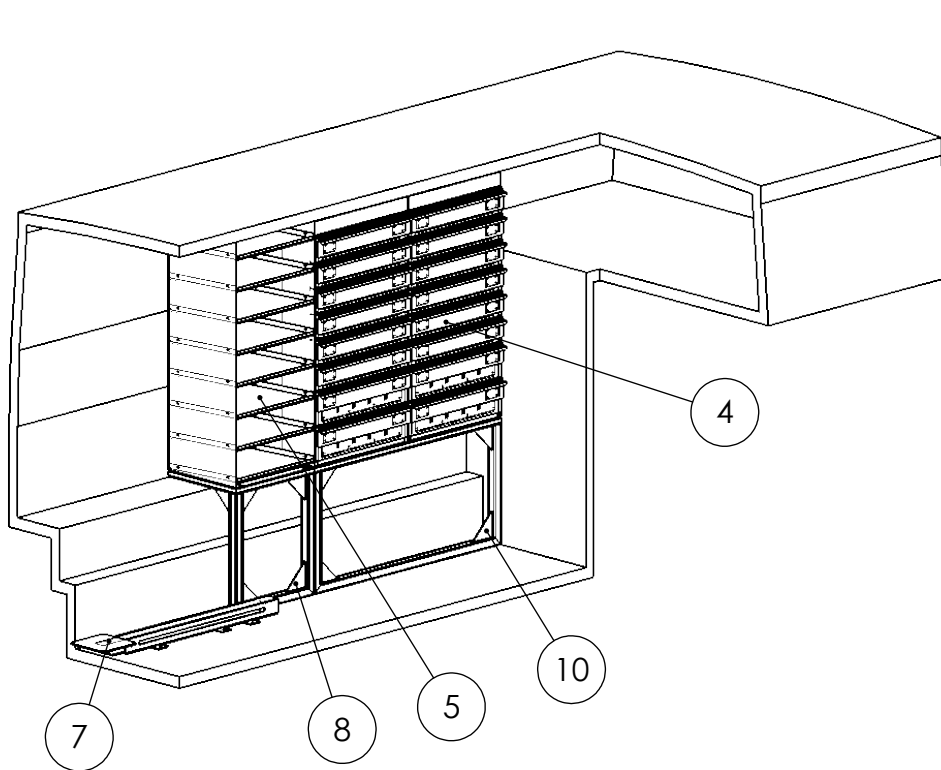

**DRIVER SIDE**

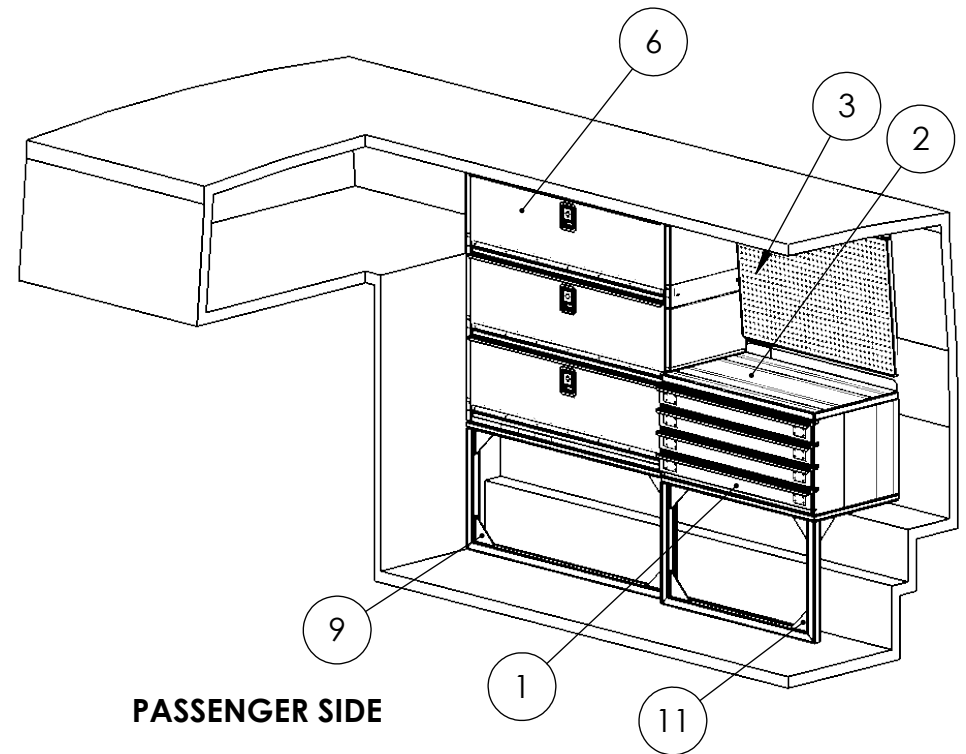

**PASSENGER SIDE**

**HALRAI**  
 HALRAI INDUSTRIES INC.  
 La Technologie au Service du Rangement  
 340 Marie Curie, Vaudreuil-Dorion, J7Y 5V5  
 Tel.: 450 455 8884 : Fax: 450 455 6902  
 www.halrai.com

Drawn by: V.I. | Date: 25-Nov-20

**EXCLUSIF ET CONFIDENTIEL**  
 LES INFORMATIONS CONTENUES DANS CETTE MISE EN  
 PLAN SONT LA PROPRIETE DE HALRAI INDUSTRIES INC.  
 TOUTE REPRODUCTION PARTIELLE OU TOTALE SANS  
 L'AUTORISATION ECRITE DE HALRAI INDUSTRIES INC.  
 EST INTERDITE.

TITLE:  
 LAYOUT MARANDA V-365 8'

P/N:  
**HAM-P.E.G-FIBRE-01**

Project/Customer: \_\_\_\_\_ REV  
**0**

P/O: \_\_\_\_\_ W/O: \_\_\_\_\_

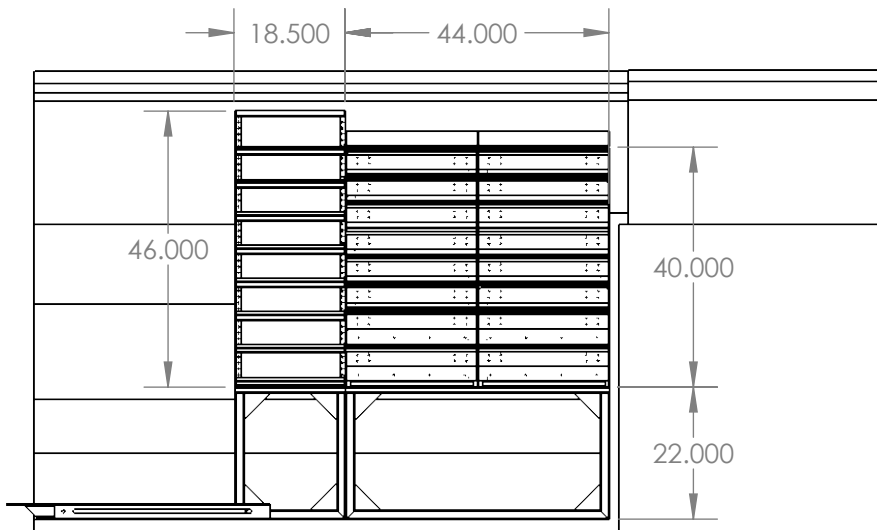

**DRIVER SIDE**

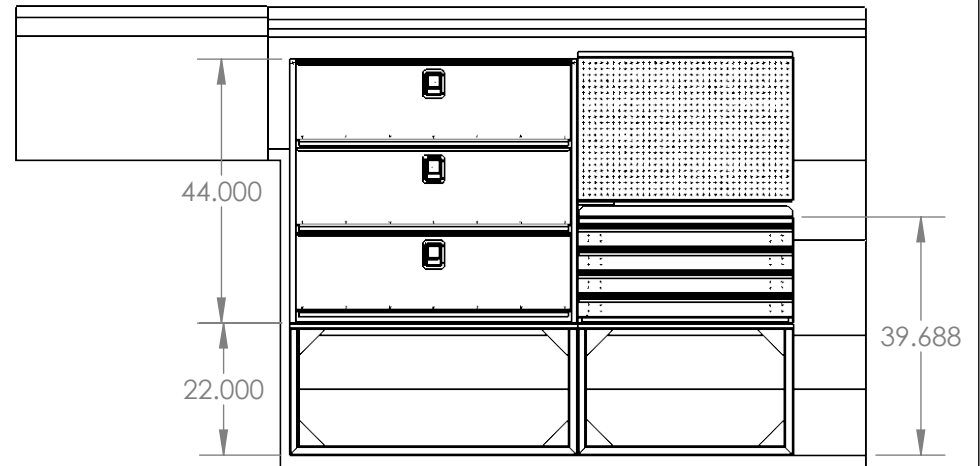

**PASSENGER SIDE**

 <b>HALRAI INDUSTRIES INC.</b> <i>La Technologie au Service du Rangement</i> 340 Marie Curie, Vaudreuil-Dorion, J7Y 5V5 Tel.: 450 455 8884 : Fax: 450 455 6902 <a href="http://www.halrai.com">www.halrai.com</a>	TITLE: LAYOUT MARANDA V-365 8'	
	P/N: <b>HAM-P.E.G-FIBRE-01</b>	
Drawn by: V.I.   Date: 25-Nov-20	Project/Customer:	REV <b>0</b>
EXCLUSIF ET CONFIDENTIEL LES INFORMATIONS CONTENUES DANS CETTE MISE EN PLAN SONT LA PROPRIETE DE HALRAI INDUSTRIES INC. TOUTE REPRODUCTION PARTIELLE OU TOTALE SANS L'AUTORISATION ECRITE DE HALRAI INDUSTRIES INC. EST INTERDITE.	P/O:	W/O:

WEIGHT: 1396.37 LBS