

SECTION A-A
SCALE 1 : 16

 HALRAI INDUSTRIES INC. <i>La Technologie au Service du Rangement</i> 340 Marie Curie, Vaudreuil-Dorion, J7Y 5V5 Tel.: 450 455 8884 : Fax: 450 455 6902 www.halrai.com	TITLE: MANULIFT LAYOUT	
	P/N: HAM-MANULIFT-01	
Drawn by: J.P. Date: 22-Dec-20	Project/Customer:	REV 0
EXCLUSIF ET CONFIDENTIEL LES INFORMATIONS CONTENUES DANS CETTE MISE EN PLAN SONT LA PROPRIETE DE HALRAI INDUSTRIES INC. TOUTE REPRODUCTION PARTIELLE OU TOTALE SANS L'AUTORISATION ECRITE DE HALRAI INDUSTRIES INC. EST INTERDITE.	P/O:	W/O:

WEIGHT: 3289.52 LBS

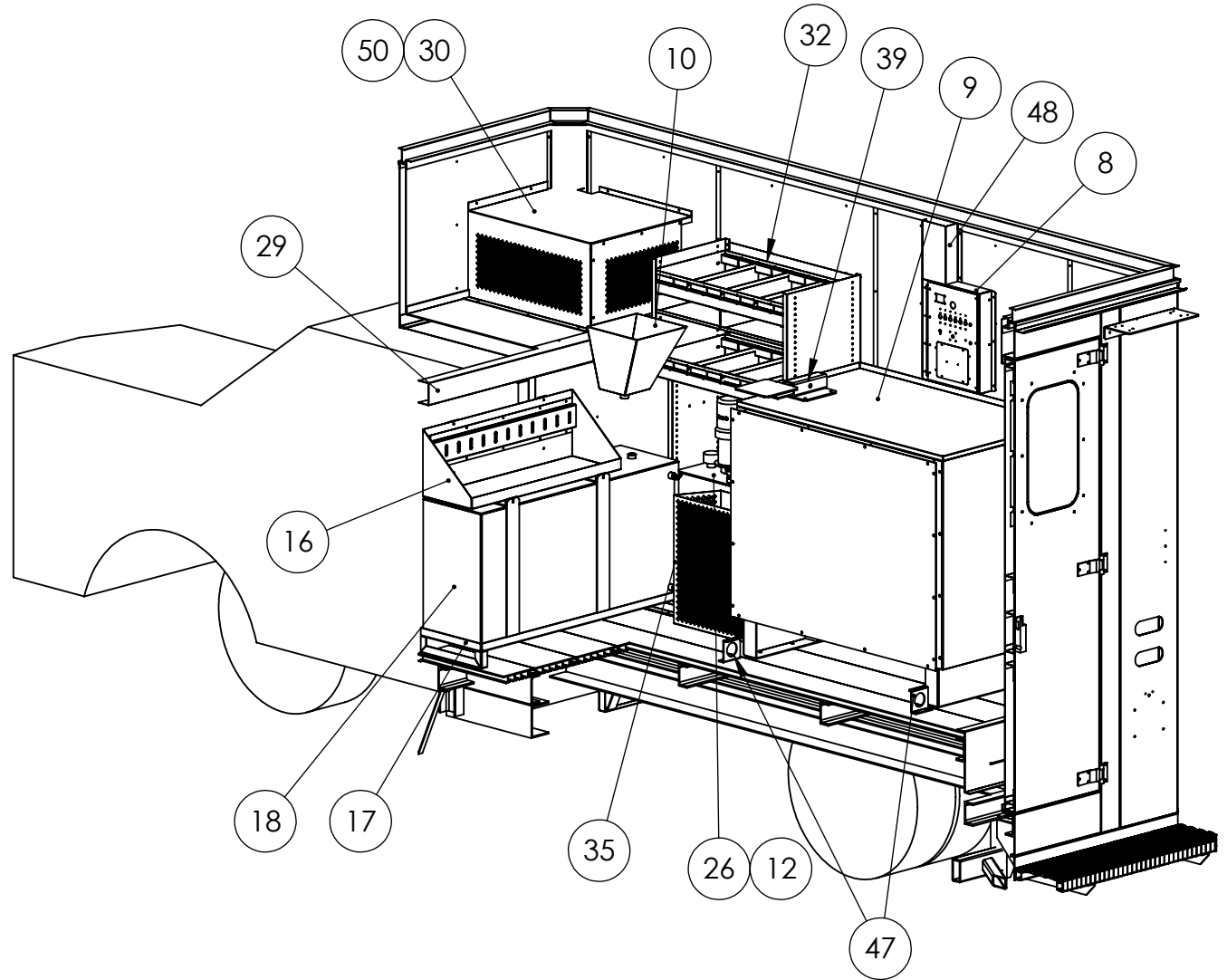
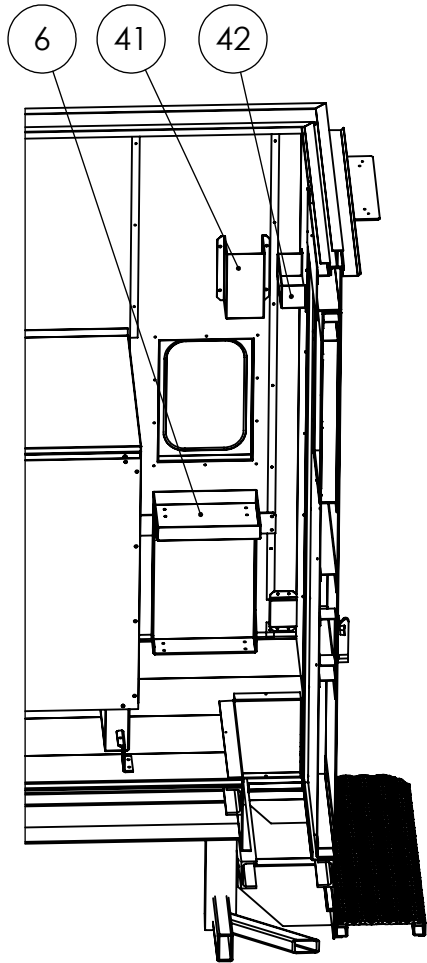

HALRAI
 HALRAI INDUSTRIES INC.
 La Technologie au Service du Rangement
 340 Marie Curie, Vaudreuil-Dorion, J7Y 5V5
 Tel.: 450 455 8884 : Fax: 450 455 6902
 www.halrai.com

Drawn by: J.P. | Date: 22-Dec-20

EXCLUSIF ET CONFIDENTIEL
 LES INFORMATIONS CONTENUES DANS CETTE MISE EN PLAN SONT LA PROPRIETE DE HALRAI INDUSTRIES INC. TOUTE REPRODUCTION PARTIELLE OU TOTALE SANS L'AUTORISATION ECRITE DE HALRAI INDUSTRIES INC. EST INTERDITE.

TITLE: MANULIFT LAYOUT	
P/N: HAM-MANULIFT-01	
Project/Customer:	REV 0
P/O:	W/O:

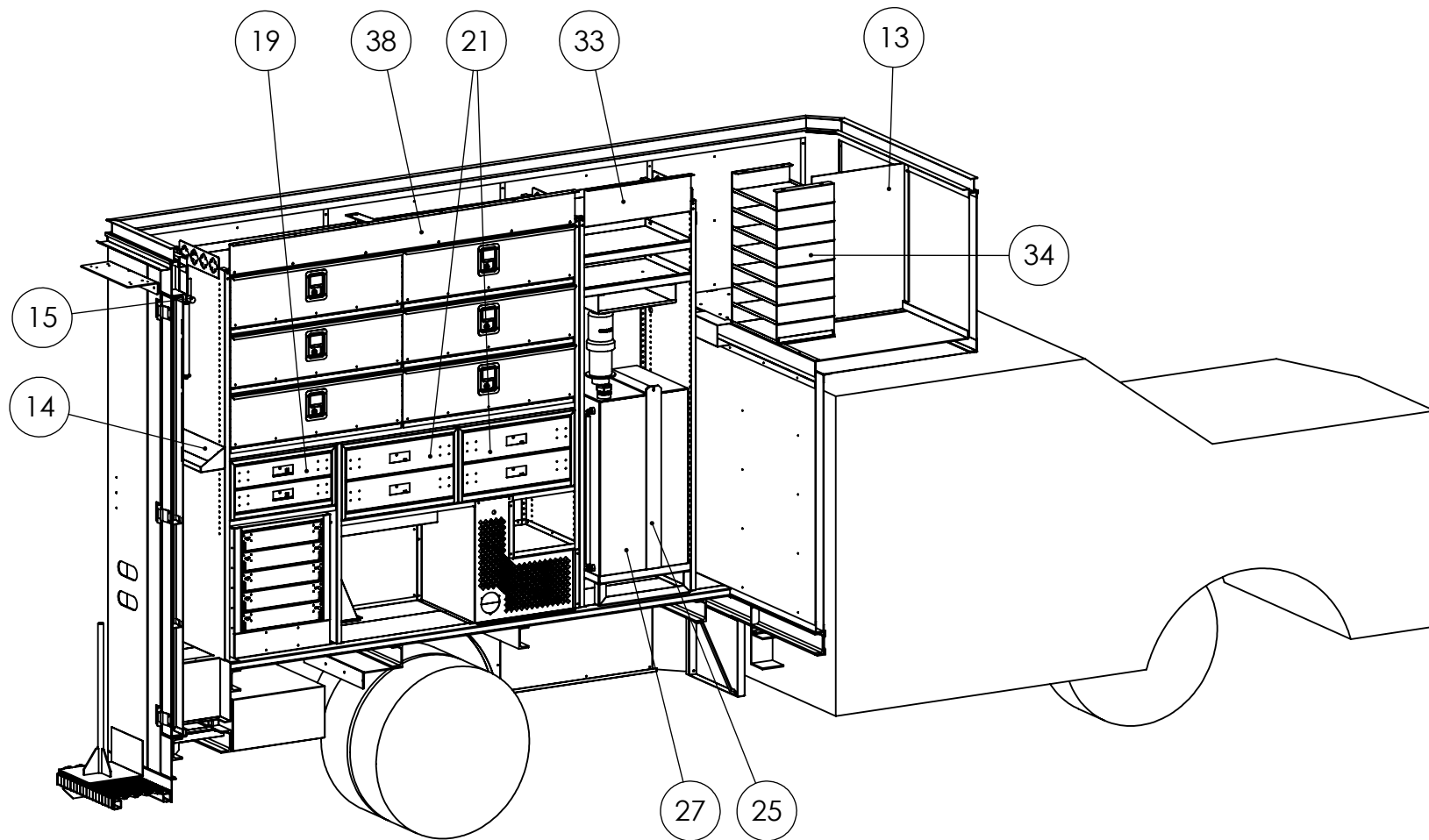

HALRAI INDUSTRIES INC.
La Technologie au Service du Rangement
 340 Marie Curie, Vaudreuil-Dorion, J7Y 5V5
 Tel.: 450 455 8884 : Fax: 450 455 6902
www.hairai.com

Drawn by: J.P. | Date: 22-Dec-20

EXCLUSIF ET CONFIDENTIEL
 LES INFORMATIONS CONTENUES DANS CETTE MISE EN PLAN SONT LA PROPRIETE DE HALRAI INDUSTRIES INC. TOUTE REPRODUCTION PARTIELLE OU TOTALE SANS L'AUTORISATION ECRITE DE HALRAI INDUSTRIES INC. EST INTERDITE.

TITLE: MANULIFT LAYOUT

P/N: **HAM-MANULIFT-01**

Project/Customer: | REV **0**

P/O: | W/O:

Item	Part number	Title	Qty	Item	Part number	Title	Qty
29	HAM-MANULIFT-01_01	HOSE COVER	1	1	FORD F450 (TRUCK) 60 CA DRW STANDARD CAB	F450 CHASSIS CAB 60 CA, DRW 4X4	1
30	HAM-MANULIFT-01_A01	ELECTRICAL COVER	1	2	HKAP-F450-CH-60CA-DRW-01	KAPALCO BOX	1
31	HSU-6.6.7-01	GAS OUTLET CAP (INSIDE KAPALCO BOX)	1	3	HBT-38.50.32-1R-01	GENERATOR BOX AIR & ARC 150 REMOVABLE BACK PANEL (MANULIFT)	1
32	HMT-62.33.18-2S-4-01	SHELF MODULE	1	4	HSU-05.45.24-01	AIR N ARC 150 SMALL TANK+BIG GAS TANK (MANULIFT)	1
33	HMT-72.24.18-2H-2-01	2X SHELVING MODULE	1	5	HSU-07.03.30-01	GENERATOR SUPPORT BRACKETS AIR N ARC 150	1
34	HSV-FLAMBEAU-724-2-8	BRIEFCASE MODULE (FLAMBEAU 724-2)	1	6	HSU-22.14.10-01	TORCH KIT SUPPORT (MANULIFT) LINCOLN: KH990	1
35	HAC-23.18.08-01	HAMMER BOX	1	7	HSU-28.11.11-01	CONE RACK	1
36	HSU-7.29.56-01	CABINET SUPPORT (F250/F350/F450 SUPERCAB)	1	8	HEL-047	ELECT. PANEL WITH DOOR (MANULIFT)	1
37	HSU-10.12.04-01	HYDRONIC ESPAR BRACKET	1	9	HET-01.50.30-01	WORKBENCH S.S.	1
38	HMT-72.73.19-6L-3S-4-01	SHELF MODULE	1	10	HRE-12.12.12-01	OIL PAN	1
39	HSU-VICE-01	VICE SUPPORT	1	11	HSU-02.15.21-01	4X BATTERY BOX ASSEMBLY (ENERWATT WPHR6-225)	1
40	HAR-36.50.16-2R-2S-1-01	2X STORAGE BOX WITH 2X SHELVES	1	12	HSU-05.15.13-01	SUPPORT FOR TANK 14-3/8W x 12-3/8D	2
41	HAC-10.5.5-01	SUPPORT EXTINGUEUR	1	13	HAM-MANULIFT-01_04	OVERHANG DIVIDER	1
42	HW-080	FIRST AID KIT BOX	1	14	HSU-04.19.05-01	REEL HOSE END SUPPORT	1
43	HSU-0156A	COMPRESSOR VENT TUBE BRACKET	1	15	HSU-GUIDE-01	REELS GUIDE	1
44	HSU-0156B	COMPRESSOR VENT TUBE BRACKET	1	16	HSU-12.37.12-01	FREON TANK SUPPORT	1
45	HSU-0152	AIR & ARC EXHAUST FLANGE (FOR HBT-38.50.32-1R-01)	2	17	HSU-3.49.15-01	SUPPORT FOR TANK	1
46	HEL-053	WIRING PASS THROUGH	1	18	HRE-24.48.14-01	USED OIL TANK 264L	1
47	HAC-001	BRACKET FOR ABS PIPE Ø2-3/8" EXT.	2	19	HCT-11.22.19-2I-2T-R1-01	2X DRAWER TRIMARK	1
48	HAM-MANULIFT-01_05	WIRING COVER	1	20	HCT-13.22.20-2I-CB-R0-01	2x DRAWER BLUE KNOB	1
49	HSU-0160	UNDER TRUCK BRACKET	1	21	HCT-14.24.19-2I-2T-R1-01	2X DRAWER TRIMARK	2
50	HAM-MANULIFT-01_06	BRACKET (COIL)	1	22	HCT-29.24.21-6I-CB-R0-01	6X DRAWER MODULE (5X TWO WAY DRAWERS)	1
51	HSU-VICE-02	VICE BRACKET TO HITCH (OPTION)	1	23	HPO-13.22.02-1R-01	LOWER DRAWER DOOR	1
52	HSU-03.18.13	LOWER DRAWER ENCLOSURE BRACKET	1	24	HPO-25.29.02-1R-01	UPPER DRAWER DOOR	1
				25	HSU-7.19.19-01	SUPPORT FOR TANK	1
				26	HRE-19.15.13-01	NEW OIL TANK 48L	2
				27	HRE-33.18.18-01	NEW OIL TANK 175L	1
				28	HSU-0155	AIR N ARC 150 WIRE HOLDER BRACKET	1

 <p>HALRAI INDUSTRIES INC. La Technologie au Service du Rangement 340 Marie Curie, Vaudreuil-Dorion, J7Y 5V5 Tel.: 450 455 8884 : Fax: 450 455 6902 www.hairai.com</p>	TITLE: MANULIFT LAYOUT	
	P/N: HAM-MANULIFT-01	
	Drawn by: J.P.	Date: 22-Dec-20
<p>EXCLUSIF ET CONFIDENTIEL LES INFORMATIONS CONTENUES DANS CETTE MISE EN PLAN SONT LA PROPRIETE DE HALRAI INDUSTRIES INC. TOUTE REPRODUCTION PARTIELLE OU TOTALE SANS L'AUTORISATION ECRITE DE HALRAI INDUSTRIES INC. EST INTERDITE.</p>	Project/Customer:	REV 0
	P/O:	W/O: