

Item	Part number	Title	Qty
1	FORD TRANSIT 148WB (LONG) HIGH ROOF		1
2	HET-01.60.24-01	WORK BENCH	1
3	HCT-38.30.24-7SL-2N-R1-01	7X DRAWER MODULE SPRING LOADED FACE	1
4	HCT-38.30.24-8SL-2N-R1-01	8X DRAWER MODULE SPRING LOADED FACE	1
5	HMC-42.48.25-01	COMBINED MODULE	1
6	HSU-0047	VICE SUPPORT ASSEMBLY	1
7	HAC-3.2-F-01	MOVABLE HOOK FOR 4" TABLETTE	2
8	HTB-48.12-01	BIO20 BIN SHELF	1
9	HW-080	FIRST AID KIT BOX	1
10	HBT-0005	SUPPORT EXTINGUISHER 5LBS & FLARE KIT (GROTE-A22-15489)	1
11	HRE-40.11.16-01	USED OIL TANK 60L	1
12	HSV-24.19.16-CF-4-01	BRIEFCASE MODULE 4X (CRAFTSMAN CMST 14520)	1
13	HMT-60.54.16-4H-4-01	SHELF MODULE	1
14	HCL-75.58.2-05B	PARTITION TRANSIT HIGH ROOF STANDARD (+2") AVEC TROUS	1

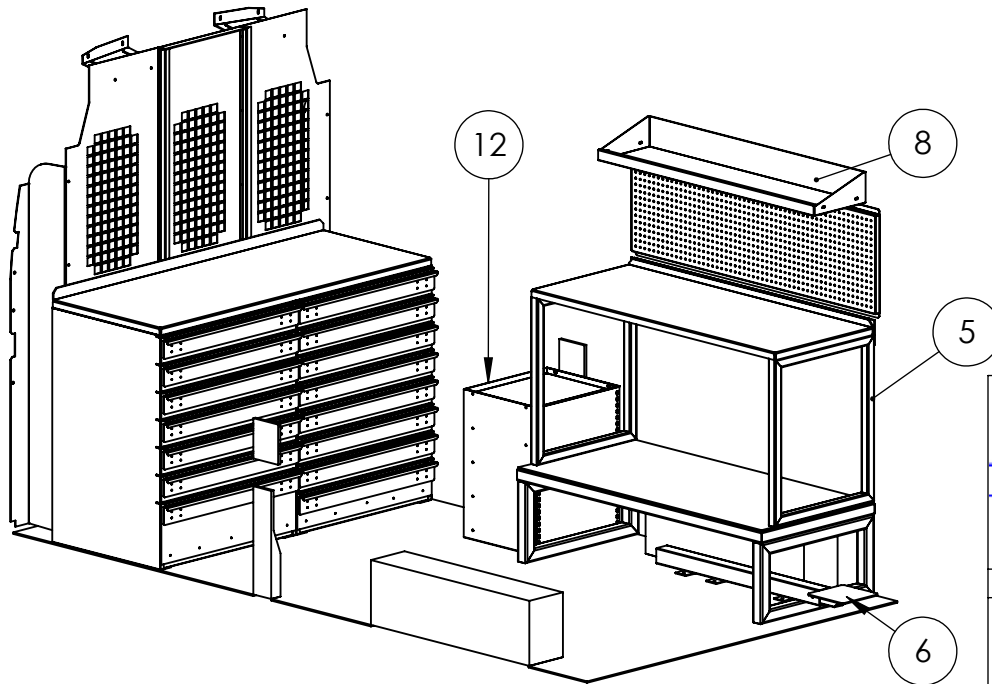

HALRAI
 HALRAI INDUSTRIES INC.
 La Technologie au Service du Rangement
 340 Marie Curie, Vaudreuil-Dorion, J7V 5V5
 Tel.: 450 455 8884 : Fax: 450 455 6902
 www.halrai.com

Drawn by: J.P. | Date: 19-Jan-21

EXCLUSIF ET CONFIDENTIEL
 LES INFORMATIONS CONTENUES DANS CETTE MISE EN PLAN SONT LA PROPRIETE DE HALRAI INDUSTRIES INC. TOUTE REPRODUCTION PARTIELLE OU TOTALE SANS L'AUTORISATION ECRITE DE HALRAI INDUSTRIES INC. EST INTERDITE.

TITLE:
 FORD TRANSIT HIGH ROOF,
 148WB, LONG LAYOUT

P/N:
HAM-MACHINERIE-CH-02

Project/Customer: | REV
0

P/O: | W/O: