

DRIVER SIDE

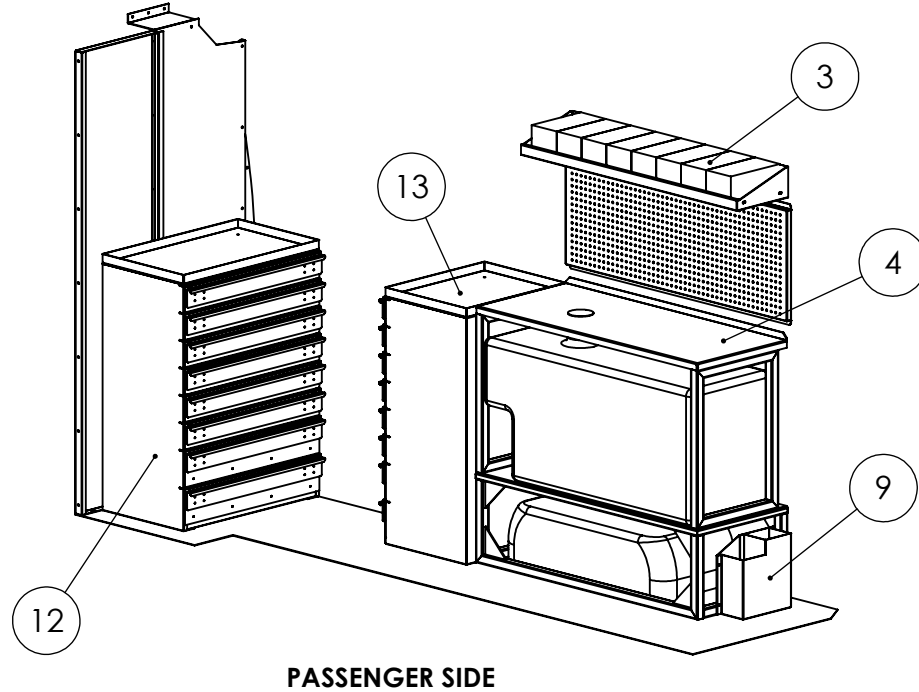

PASSENGER SIDE

Item	Part number	Title	Qty
1	HCL-SPR-H-01	MB SPRINTER HIGHT ROOF WITH FOAM PARTITION WITHOUT DOOR	1
2	HSU-12.26.17-01	SUPPORT 2X TANK & GRILL ESPAR	1
3	HTB-05.48.12-01	BIO20 BIN SHELF	1
4	HMC-42.49.20-01	WORK BENCH WITH PEGBOARD	1
5	HMT-60.48.21-3H-X-02	SHELF MODULE	1
6	HMT-60.48.21-3H-X-03	SHELF MODULE	1
7	HSU-24.19.10-01	TANK HOLDER (2X) ASSY	1
8	HW-080	FIRST AID KIT BOX	1
9	HBT-0005	SUPPORT EXTINGUISHER & TRIANGLE KIT	1
10	HSU-24.09.10-01	TANK HOLDER (1X 7 1/2 DIA) ASSY	1
11	HAC-3.2-F-01	MOVABLE HOOK FOR 4" TABLETTE	1
12	HCT-40.30.18-8SL-2N-R1-02	8X DRAWER MODULE SPRING LOADED FACE	1
13	HCT-40.22.18-8SL-2N-R1-02	8X DRAWER MODULE SPRING LOADED FACE	1

HALRAI INDUSTRIES INC.
 La Technologie au Service du Rangement
 340 Marie Curie, Vaudreuil-Dorion, J7Y 5V5
 Tel.: 450 455 8884 : Fax: 450 455 6902
www.hairai.com

Drawn by: V.I. | Date: 24-Sep-20

EXCLUSIF ET CONFIDENTIEL
 LES INFORMATIONS CONTENUES DANS CETTE MISE EN PLAN SONT LA PROPRIETE DE HALRAI INDUSTRIES INC. TOUTE REPRODUCTION PARTIELLE OU TOTALE SANS L'AUTORISATION ECRITE DE HALRAI INDUSTRIES INC. EST INTERDITE.

TITLE:
 LAYOUT MB SPRINTER 3500
 144'WB DWR HIGH ROOF

P/N:
HAM-LONGUS-SPRINTER-H-01

Project/Customer: _____ REV
0

P/O: _____ W/O: _____