

Item	Part number	Title	Qty
1	DODGE RAM PROMASTER 3500 159WB EXTENDED	RAM PROMASTER 3500 159WB EXTENDED	1
2	HAR-60.24.18-1R-1S-2-03	LOCKER	1
3	HMT-72.60.18-5H-4-01	SHELF MODULE TRANSIT HIGH ROOF	1
4	HMT-72.48.18-1L-5H-4-01	SHELF MODULE PROMASTER HIGH ROOF	1
5	HMC-72.48.18-1L-2H-4-01	SHELF MODULE PROMASTER HIGH ROOF	1
6	HAC-10.5.5-01	SUPPORT EXTINCTEUR	1

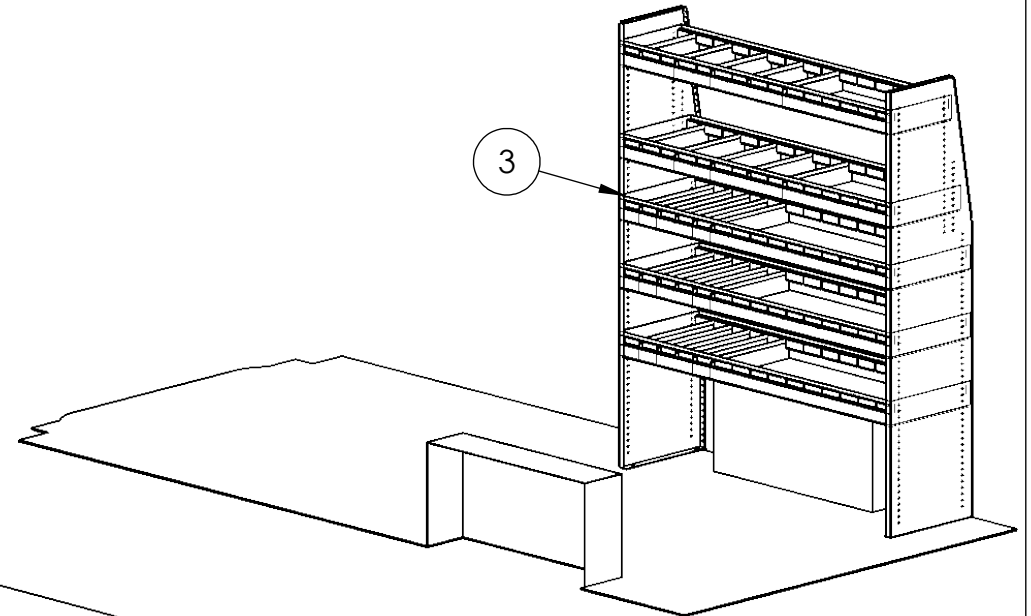
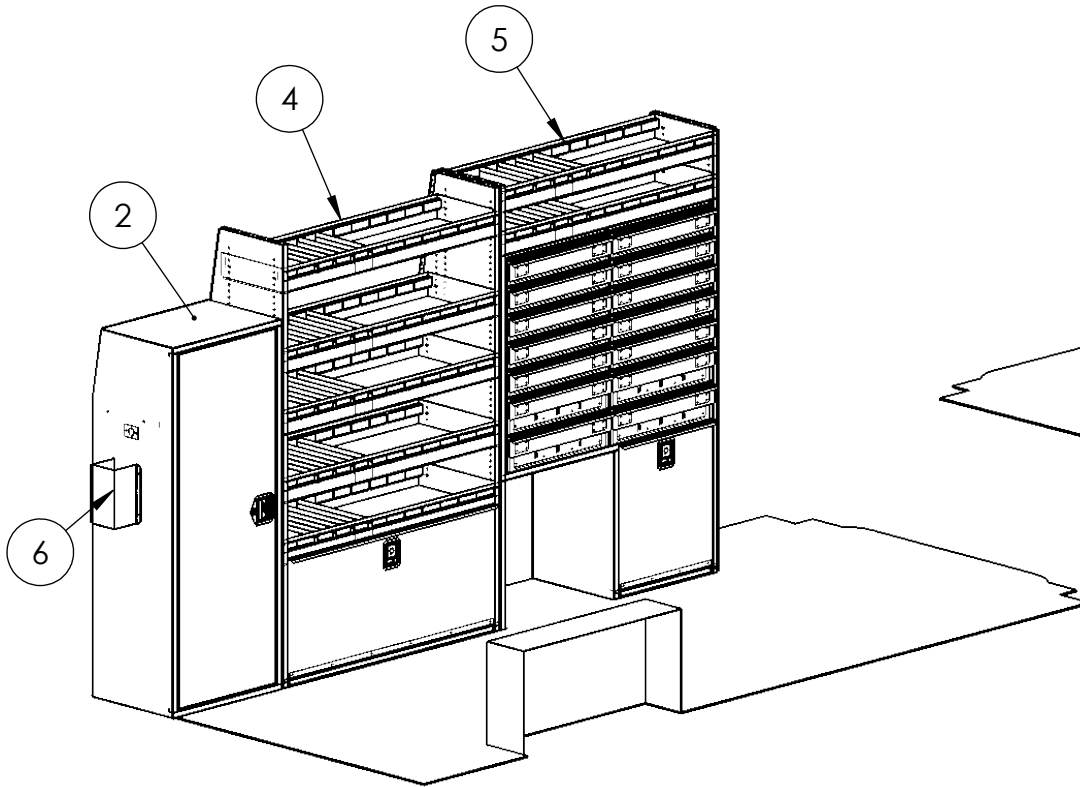

HALRAI
 HALRAI INDUSTRIES INC.
 La Technologie au Service du Rangement
 340 Marie Curie, Vaudreuil-Dorion, J7Y 5V5
 Tel.: 450 455 8884 : Fax: 450 455 6902
 www.halrai.com

Drawn by: J.P. | Date: 10-Nov-20

EXCLUSIF ET CONFIDENTIEL
 LES INFORMATIONS CONTENUES DANS CETTE MISE EN PLAN SONT LA PROPRIETE DE HALRAI INDUSTRIES INC. TOUTE REPRODUCTION PARTIELLE OU TOTALE SANS L'AUTORISATION ECRITE DE HALRAI INDUSTRIES INC. EST INTERDITE.

TITLE:
 PROMASTER HIGH ROOF, 159WB
 EXTENDED LAYOUT

P/N:
HAM-BIGRAS-VITRE-HAW-01

Project/Customer: | REV
0

P/O: | W/O: