

Item	Part number	Title	Qty	Item	Part number	Title	Qty
9	HSU-13.15.21-01	FOLDABLE STEP HITCH	1	1	MARANDA V375 8'	MARANDA FIBERGLASS BOX V365 8'	1
10	HSU-24.19.10-01	TANK HOLDER (2X) ASSY	1	2	HMT-36.50.24-2L-2S-4-01	SHELF MODULE	1
11	HAC-28.50.0-01	PEG BOARD	1	3	HET-01.50.26-01	WORK BENCH	1
12	HSU-0047	VICE SUPPORT ASSEMBLY	1	4	HSU-22.30.20-01	SUPPORT DRAWER MODULE	1
13	HBT-39.38.30-1R-01	GENERATOR BOX VMAC MULTIFUNCTION	1	5	HSU-22.52.20-01	SUPPORT TABLETTE MODULE & TANK HOLDER	1
14	HSU-5.33.25-01	MOVABLE DRAWER FOR VMAC 2X BATTERY BOX ASSEMBLY (NORTHSTAR & POL-31 AGM BATTERY)	1	6	HSU-23.38.22-01	SUPPORT VMAC	1
15	HSU-2.27.7-01		1	7	HCT-40.30.20-8I-2N-R1-01	CABINET 8X DRAWERS NO HANDLES	1
				8	HMT-44.42.20-3L-4S-4-01	4" SHELVING MODULE	1

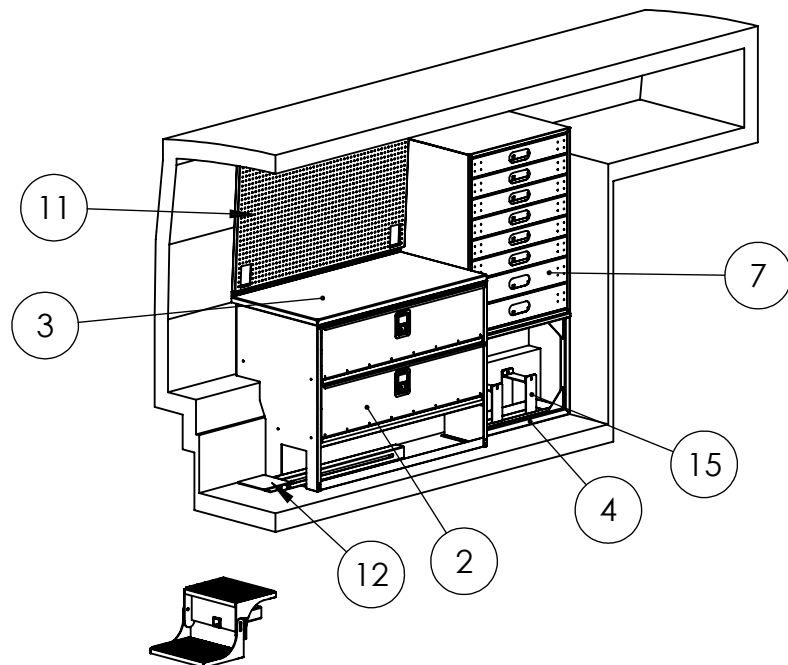

13 14

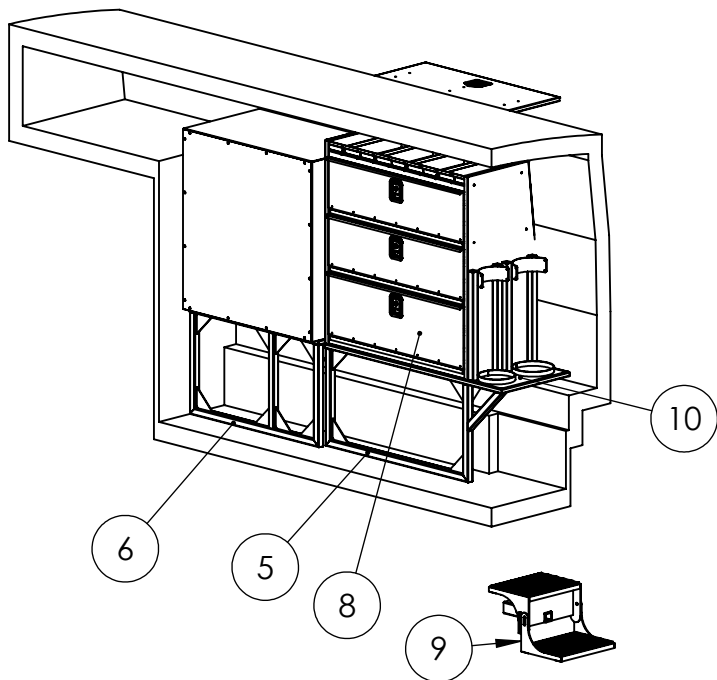

HALRAI
 HALRAI INDUSTRIES INC.
 La Technologie au Service du Rangement
 340 Marie Curie, Vaudreuil-Dorion, J7Y 5V5
 Tel.: 450 455 8884 : Fax: 450 455 6902
 www.halrai.com

Drawn by: J.P. | Date: 6-Sep-19

EXCLUSIF ET CONFIDENTIEL
 LES INFORMATIONS CONTENUES DANS CETTE MISE EN PLAN SONT LA PROPRIETE DE HALRAI INDUSTRIES INC. TOUTE REPRODUCTION PARTIELLE OU TOTALE SANS L'AUTORISATION ECRITE DE HALRAI INDUSTRIES INC. EST INTERDITE.

TITLE:
 ACE LAYOUT, MARANDA BOX

P/N:
HAM-ACE-MARANDA-01

Project/Customer: | REV
 0

P/O: | W/O: